

Sheet	RP2040	Number	1/4
Project	Doorlock Frontend v2	Revision	1
Drawn by	q3k		
License	CERN-OHL-S		
Date	2023-10-15		

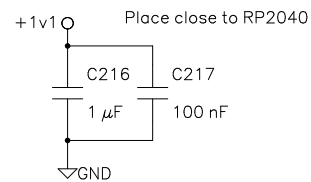

open source hardware

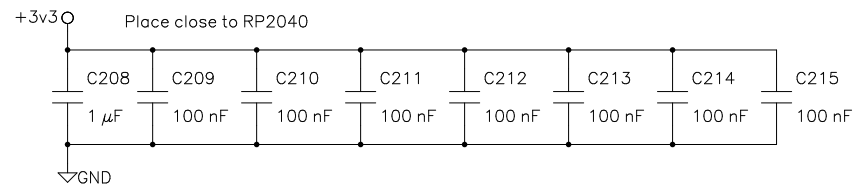
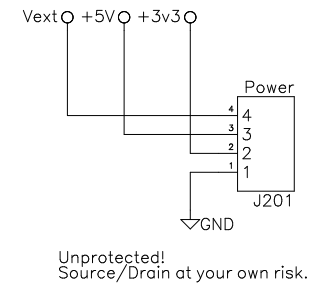
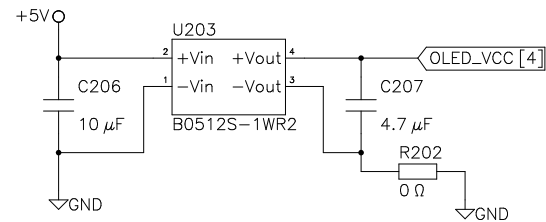
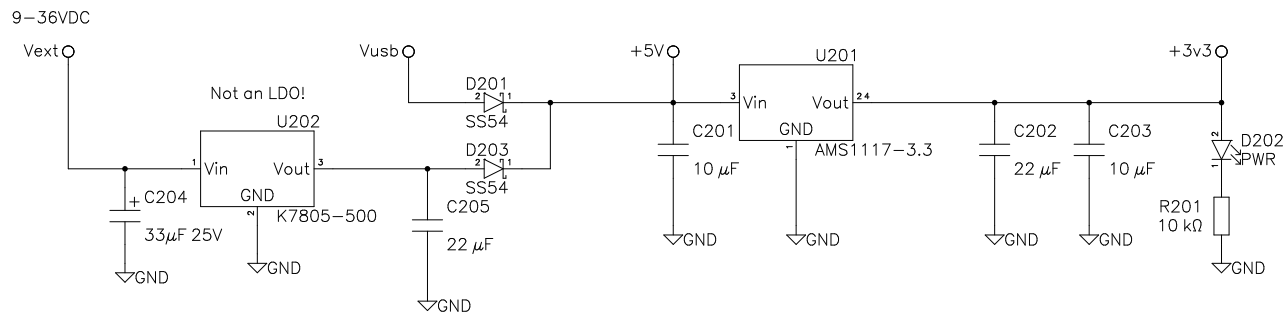

Sheet Power	Number 2/4
Project Doorlock Frontend v2	Revision 1
Drawn by q3k	
License CERN-OHL-S	
Date 2023-10-15	



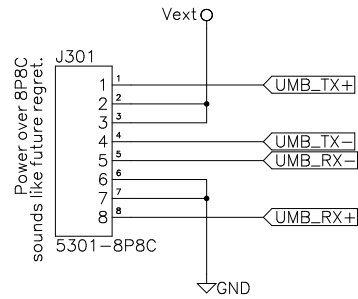

TODO: verify if termination is needed on TX, otherwise DNP.

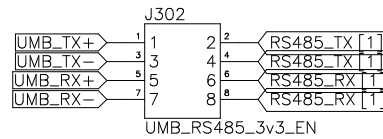
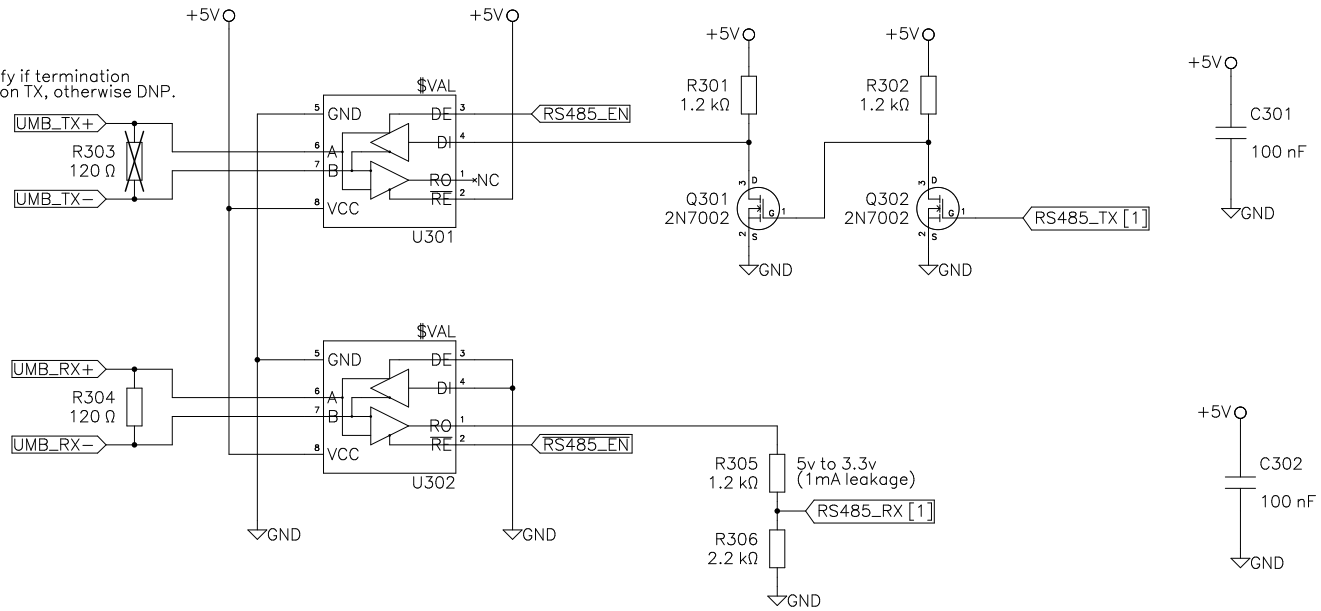

Populate to enable stopgap 3.3V UART on 8P8C.

! WARNING !
Do not populate both UMB_RS485_{3v3_EN,EN} as that will damage the RP2040!

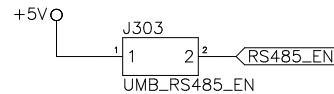

Populate to enable standard RS485 on 8P8C.

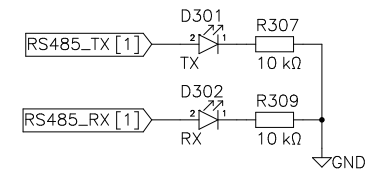
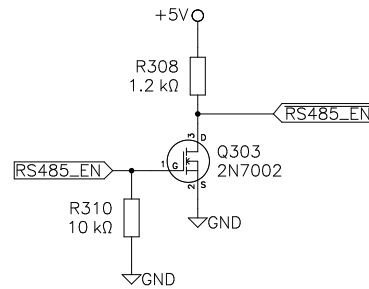

Sheet	Number
Umbilical	3/4
Project	Revision
Doorlock Frontend v2	1
Drawn by	
q3k	
License	
CERN-OHL-S	
Date	
2023-10-15	



